

28003345

LC

Tridonic, LC 15W 350mA fixC PC SR SNC2, LED Converter Compact - Leading & Trailing edge dimmable-ESSENCE, Made In PRC, 5yrs Warranty

DATA SHEET

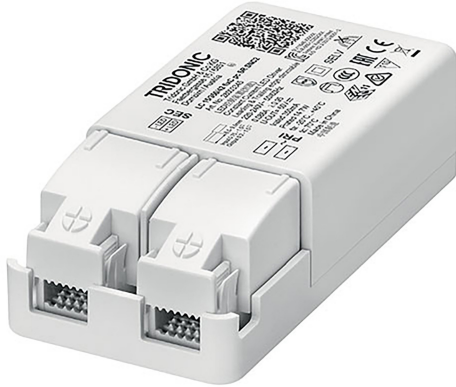

MECHANICAL SPECIFICATION

Item Nett Weight (kg)	0.085kg
Length (mm)	101.50mm
Width (mm)	49mm
Height (mm)	29mm

ENERGY SPECIFICATION

Energy Class	A++ to A
--------------	----------

ELECTRICAL & SAFETY SPECIFICATION

Protection Class	Class 2 - Double Insulated
Dimmable	No
IP Rating	IP20

LINE DRAWING

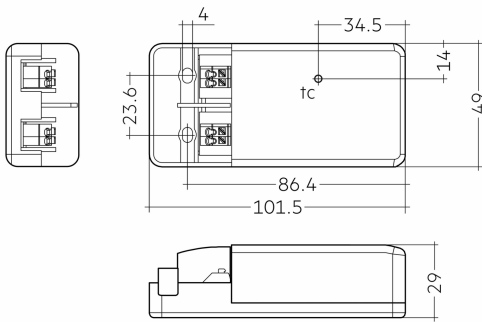

QUALITY STANDARDS

Average Life (hrs)	50000hrs
Warranty (yrs)	5yrs

[Click to view the full product details](#)

OVERVIEW

Constant current Fixed output built-in LED Driver, For luminaires of protection class I and protection class II, Temperature protection as per EN 61347-2-13 C5e, High efficiency and long life.

Inspired Lighting Ltd. are continually developing and improving their products. Technical specifications subject to change without prior notice.