

87500747

LC

Tridonic, LC 15/350/43 fixC SR SNC2, LED Converter Compact SNC2 - ESSENCE, Made In PRC, 5yrs Warranty



DATA SHEET

MARKETING INFORMATION

Brief Description	15W 350mA fixC SR SNC2 ESSENCE Constant Current LED Driver
-------------------	--

PHYSICAL CHARACTERISTICS

Colour Finish	White
---------------	-------

MECHANICAL SPECIFICATION

Item Nett Weight (kg)	0.058kg
Length (mm)	100mm
Width (mm)	43mm
Height (mm)	22.5mm

LINE DRAWING

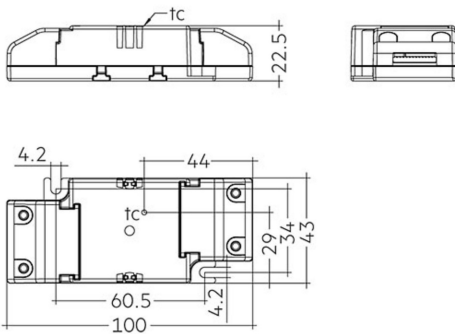

ENERGY SPECIFICATION

Energy Class	A++ to A
--------------	----------

ELECTRICAL & SAFETY SPECIFICATION

Protection Class	Class 2 - Double Insulated
IP Rating	IP20

QUALITY STANDARDS

Average Life (hrs)	50000hrs
Warranty (yrs)	5yrs

[Click to view the full product details](#)

Inspired Lighting Ltd. are continually developing and improving their products.  
Technical specifications subject to change without prior notice.