

DM201695

Bania 12

Bania 12 Powered by Tridonic 12W 1200lm 2700K 36° LED Engine, 350mA, Silver IP20 Fixed Recessed Spotlight , DRIVER NOT INC. 5yrs Warranty

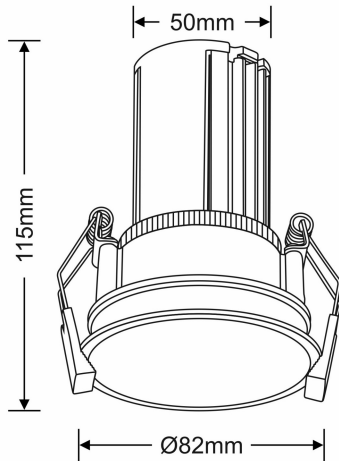

LINE DRAWING

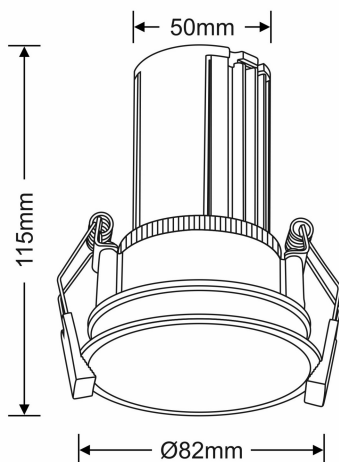

[Click to view the full product details](#)

DATA SHEET

MARKETING INFORMATION

Brief Description	Bania 12 Powered by Tridonic 12W 2700K 1200lm 36° CRI>90 LED Engine, 350mA Silver Fixed Recessed Spotlight, IP20
-------------------	--

PHYSICAL CHARACTERISTICS

Colour Finish	Silver
---------------	--------

MECHANICAL SPECIFICATION

Diameter (mm)	82mm
Height (mm)	100mm
Cut Out (mm)	76mm

ENERGY SPECIFICATION

Energy Class	A++
--------------	-----

LAMP SPECIFICATION

Lamp Socket	Integral LED
Recommended Lamp	Integral LED
Max Wattage Lamp (W)	12W
Lamp Included	Yes - Integrated
Type of Lamp Included	Integrated LED
Colour Temperature (K)	2700K Warm White (±5%)

LED SPECIFICATION

LED Voltage (V)	32.4-37.6V DC (±5%)
-----------------	---------------------

OPTICAL SPECIFICATION

Beam Angle (°)	36°
System Flux (lm)	1200lm (±5%)
CRI	>90
UGR	≤19

DRIVER SPECIFICATION

Driver Included	No
Type of Driver Required	Constant Current

ELECTRICAL & SAFETY SPECIFICATION

Protection Class	Class 3 - Low Voltage
------------------	-----------------------

Inspired Lighting Ltd. are continually developing and improving their products.
Technical specifications subject to change without prior notice.

DM201695

Bania 12

Dimmable	Yes - Suitable Driver Required
Dimmer Included	No
IP Rating	IP20

QUALITY STANDARDS

Average Life (hrs)	50000hrs
Warranty (yrs)	5yrs

OVERVIEW

Comprehensive range of Fixed spotlight recessed mount IP20 available in White, Powered by Tridonic Engine, 350mA. 3 colour temperatures, 3 beam angles, dimmable, Small colour tolerance.

Inspired Lighting Ltd. are continually developing and improving their products.
Technical specifications subject to change without prior notice.