

## DM202044

## Bolor 9

Bolor 9 Powered by Tridonic 9W 840lm 3000K 24° LED Engine, 250mA Black/White IP20 Fixed Recessed Spotlight , DRIVER NOT INC. 5yrs Warranty



### LINE DRAWING

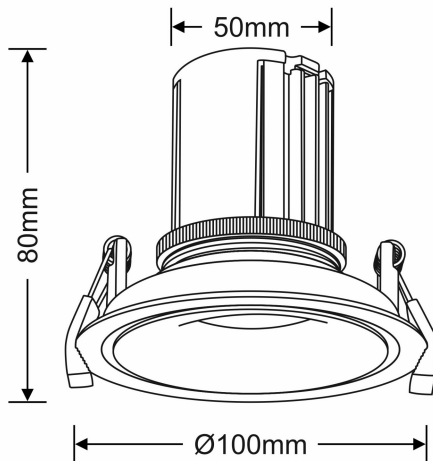

[Click to view the full product details](#)

### DATA SHEET

#### MARKETING INFORMATION

Brief Description	Bolor 9 Tridonic Powered 9W 3000K 840lm 24° CRI>90 LED Engine Black/White Fixed Recessed Spotlight, IP20
-------------------	--

#### PHYSICAL CHARACTERISTICS

Colour Finish	Black/White
---------------	-------------

#### MECHANICAL SPECIFICATION

Diameter (mm)	100mm
Height (mm)	80mm

#### ENERGY SPECIFICATION

Energy Class	A++
--------------	-----

#### LAMP SPECIFICATION

Lamp Socket	Integral LED
Recommended Lamp	Integral LED
Max Wattage Lamp (W)	9W
Lamp Included	Yes - Integrated
Type of Lamp Included	Integrated LED
Colour Temperature (K)	3000K Warm White (±5%)

#### LED SPECIFICATION

LED Voltage (V)	30-40V DC (±5%)
-----------------	-----------------

#### OPTICAL SPECIFICATION

Beam Angle (°)	24°
System Flux (lm)	840lm (±5%)
CRI	>90
UGR	≤19

#### DRIVER SPECIFICATION

Driver Included	No
Type of Driver Required	Constant Current

#### ELECTRICAL & SAFETY SPECIFICATION

Protection Class	Class 3 - Low Voltage
Dimmable	Yes - Suitable Driver Required

Inspired Lighting Ltd. are continually developing and improving their products.  
Technical specifications subject to change without prior notice.

DM202044

Bolor 9

Dimmer Included	No
IP Rating	IP20

QUALITY STANDARDS

Average Life (hrs)	50000hrs
Warranty (yrs)	5yrs

OVERVIEW

Comprehensive range of Fixed spotlight recessed mount IP20 available in Black/White, Powered by Tridonic engine, 250mA . 3 colour temperatures, 3 beam angles, dimmable, Small colour tolerance.

Inspired Lighting Ltd. are continually developing and improving their products.  
Technical specifications subject to change without prior notice.