

M6609

Infinity II

Infinity II 43cm Ceiling, 30W LED, 3000K, 2250lm, IP20, Chrome/White Acrylic/Clear Mirror, 3yrs Warranty



LINE DRAWING

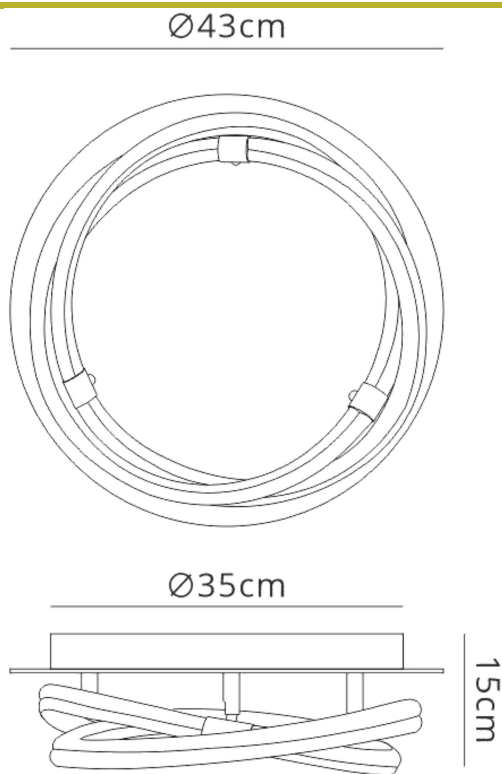

[Click to view the full product details](#)

DATA SHEET

MARKETING INFORMATION

Brief Description Infinity II Flush Ceiling 30W LED

PHYSICAL CHARACTERISTICS

Colour Finish	Polished Chrome
Colour Finish 2	Opal White
Colour Finish 3	Mirror
Ceiling Mountable	Yes

MECHANICAL SPECIFICATION

Item Nett Weight (kg)	3.9kg
Diameter (mm)	430mm
Height (mm)	150mm

ENERGY SPECIFICATION

Energy Class	G
--------------	---

LAMP SPECIFICATION

No: of Lamp	1
Lamp Socket	Integral LED
Recommended Lamp	Integral LED
Max Wattage Lamp (W)	30W
Lamp Included	Yes - Integrated
Type of Lamp Included	Integrated LED
Colour Temperature (K)	3000K Warm White (±5%) (±5%)

OPTICAL SPECIFICATION

Beam Angle (°)	120°
System Flux (lm)	2250lm (±5%) (±5%)
CRI	>80

DRIVER SPECIFICATION

Driver Included	Yes
-----------------	-----

ELECTRICAL & SAFETY SPECIFICATION

Protection Class	Class 1 - Earth Connection Required
Dimmable	No
IP Rating	IP20

QUALITY STANDARDS

Inspired Lighting Ltd. are continually developing and improving their products. Technical specifications subject to change without prior notice.

M6609

Infinity II

Average Life (hrs)	30000hrs
Warranty (yrs)	3yrs

OVERVIEW

Mantra have always prided themselves in being at the forefront of inventive and innovative design, this second generation of the Infinity collection is no exception. The first of its kind in the lighting industry, Infinity II offers an astounding 360 degree illumination giving a completely ambient array of light dispersion. The clover shaped moulding of the acrylic tubes dispels the 3000K LEDs evenly for optimum lighting output.

Inspired Lighting Ltd. are continually developing and improving their products.  
Technical specifications subject to change without prior notice.