

M7983

Esparta

Esparta Linear Pendant, 50W LED, 3000K, 2100lm, Black / Gold, 3yrs Warranty



LINE DRAWING

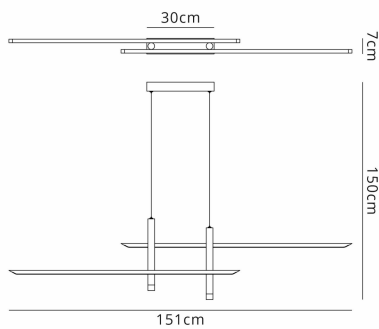

[Click to view the full product details](#)

DATA SHEET

MARKETING INFORMATION

Brief Description Esparta Pendant 50W LED Black

PHYSICAL CHARACTERISTICS

Colour Finish Black
Colour Finish 2 Gold
Ceiling Mountable Yes

MECHANICAL SPECIFICATION

Item Nett Weight (kg) 1.3kg
Length (mm) 1530mm
Width (mm) 70mm
Minimum Drop (mm) 450mm
Maximum Drop (mm) 1500mm

ENERGY SPECIFICATION

Energy Class A++ to A

LAMP SPECIFICATION

No: of Lamp 1
Lamp Socket Integral LED
Recommended Lamp Integral LED
Max Wattage Lamp (W) 50W
Lamp Included Yes - Integrated
Type of Lamp Included Integrated LED
Colour Temperature (K) 3000K Warm White (±5%)

LED SPECIFICATION

LED Voltage (V) 3.0-3.2V (±5%)

OPTICAL SPECIFICATION

Beam Angle (°) 120°
System Flux (lm) 2100lm (±5%)
CRI >80

DRIVER SPECIFICATION

Driver Included Yes

ELECTRICAL & SAFETY SPECIFICATION

Protection Class Class 2 - Double Insulated
Dimmable No

Inspired Lighting Ltd. are continually developing and improving their products.
Technical specifications subject to change without prior notice.

M7983

Esparta

IP Rating IP20

QUALITY STANDARDS

Average Life (hrs)	30000hrs
Warranty (yrs)	3yrs

OVERVIEW

Both the black and white colour finishes in the Esparta collection have gold accents to add an amplified aura of modern design. The high quality LEDs sit within slim metal tubes aswell as the long bar that they sit between. These complete frames are suspended to produce a unique linear pendant light available in two sizes.

Inspired Lighting Ltd. are continually developing and improving their products.
Technical specifications subject to change without prior notice.